



# Accessibility

## EasyPlat and DomoStep

*Platform lifts for low and medium travel*



MADE IN ITALY





Whether there are a few steps to overcome or a height difference of a few metres, AreaLift guarantees the ideal solution for every need.





# AreaLift

Range of products for accessibility



AreaLift is the company specialised in the removal of architectural barriers, both in public and domestic premises. Our solutions have a smooth impact in your location thanks to the highly designed structures and to the glass surfaces. The whole range can be installed in a few hours or in a few days depending on the product type. All the products require reduced building work: we take care of everything!



## DomoFlex 2

The DomoFlex platform lift is perfect for connecting floors both indoors and outdoors, such as lofts, penthouses, terraces, balconies and all those situations where the fixing points are limited  
Maximum travel:  
**15 metres.**

See specific catalog



## EasyPlat



Our lifting platform designed for overcoming architectural barriers. Ideal for two people standing or a wheelchair user and another person. Maximum travel: **3 metres**.

Page 6

## DomoStep



The open platform, DomoStep 100A is the ideal solution to overcome architectural barriers **up to 1 metre**, in total safety. Designed specifically for people with reduced mobility or wheelchairs, alone or with another person.

Page 12

# EasyPlat

Lifting platform without shaft



## Versatile solution

EasyPlat is the lifting platform solution for all environments: a house, a block of flats or any public buildings such as offices, shops or restaurants.

It guarantees full comfort and has been designed to overcome a small travel like a few steps or even an entire floor in complete safety up to 3 metres travel.

## Why choose EasyPlat

- 🏠 Maximum level of safety
- 🏠 Take advantage of most of the available space
- 🏠 Extremely quiet
- 🏠 Easy maintenance
- 🏠 Quick installation time: maximum 1 day
- 🏠 Italian style, with sophisticated design, LED strips and double control panels
- 🏠 Absence of building works (no pit needed)
- 🏠 Minimal aesthetic impact
- 🏠 Can be installed both outdoor and indoor
- 🏠 Made in Parma, Italy



Outdoor



Indoor



Suggested  
use



Max payload



230 VAC  
Single-phase



### Stylish for the home

EasyPlat has been designed to fit all environments including domestic properties.

The EasyPlat **neat design offers unique details** thanks to the stylishly shaped profiles, lighting with LED strips and large glass panels.

### Simple, thanks to the absence of building works

EasyPlat simply stands on the floor.

It has an integrated ramp for access and egress and it does not require a pit.

Load-bearing walls are not required.

EasyPlat requires minimal space, it does not require a machine room or any external cabinet.

# EasyPlat



## Perfect for a block of flats

EasyPlat can be installed in a block of flats to help everyone overcome small travels.

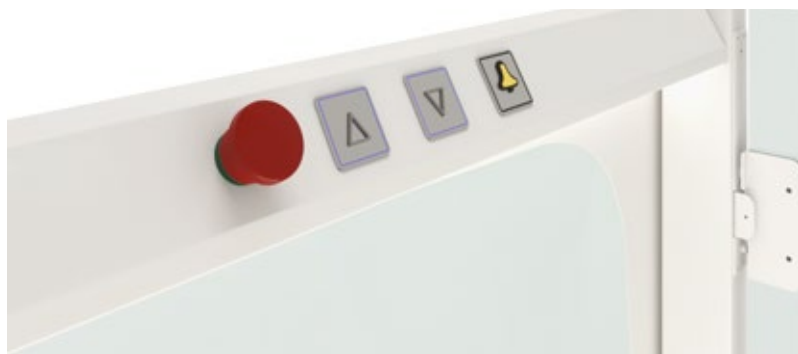

EasyPlat is activated by pressing a button, both on the platform and at the arrival floor. It is equipped with **double control panels on both sides**. The column or the wall-mounted push-button panel, both with wireless buttons, can be positioned to suit.





### Functional in any public environment

EasyPlat is the ideal solution to overcome architectural barriers in public environments. It will ensure easy access for everyone in schools, shops, restaurants and offices.



LED lighting, improves the design of the product and helps to visualise its overall dimensions in the dark ensuring higher safety.

### Quick and easy to install

EasyPlat can be installed in a short time:  
**less than one day!**

The main components are pre-assembled supplied to simplify and speed up the installation process.

The possibility of adjusting the travel +/- 50 mm on site avoids small and annoying steps that you can find between the platforms and the finished floor.

# EasyPlat

## Finishes

### Lift guides and guide infill panel

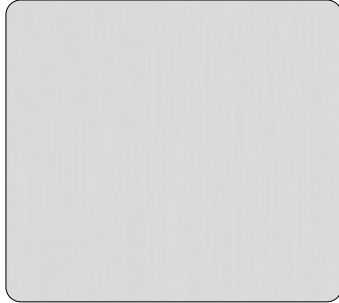

Anodized aluminium  
**Standard**

### Platform painting

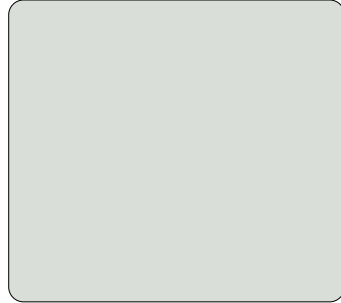

RAL 7035 - Light grey  
**Standard**

### Glass

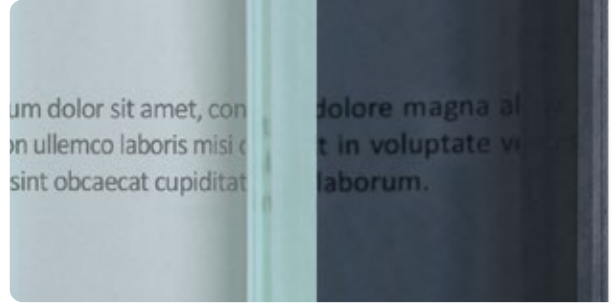

Natural  
**Standard**

Smoke Grey  
**Optional**

### RAL painting | AreaLift range - Optional for platform and / or guide infill panel



## Floors

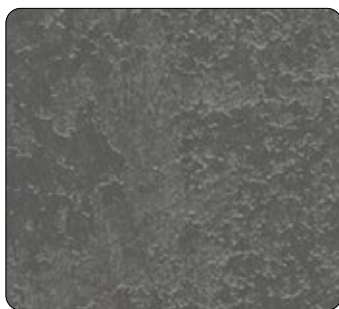

**2810 - Cement**  
Multilayer laminate



**Aluminium**  
5 bar aluminium tread plate

## COP and buttons

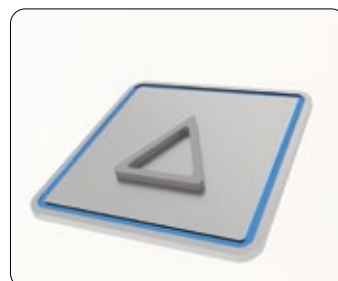
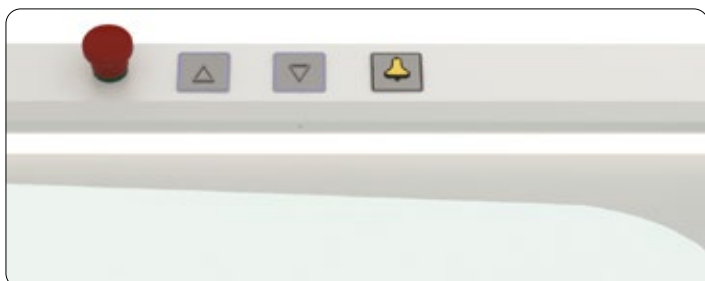

- 🏠 54 x 54 mm control buttons with embossed decoration
- 🏠 Matt steel colour finish
- 🏠 Blue backlight
- 🏠 IP54 rated protection

# EasyPlat

## Technical specifications

Travel	Max 3000 mm Min. 600 mm
Installation adjustment	+/- 50 mm
Load	400 kg
Stops	2 Max
Entrances	Front and rear only
Controls	Hold-to-run button
Installation	Indoor or outdoor
Platform dimensions (L1xL2)	1100 x 1400 mm 900 x 1400 mm 900 x 1250 mm
Minimum headroom required	1600 mm
Pit depth	Not required: integrated ramp Floor height: 70 mm
Drive	Electromechanical motor with belt
Operation	Push button
Remote Control	2 pieces kit (standard)
Maximum speed	Max 0.10 m/sec (6 m/min)
Cycles/hour	10 max
Temperatures range	-5°C / + 40°C
Noise	less than 30 dB
Power supply	Single-phase 230 Vac - 50-60 Hz
Installed power	1.1 kW
Max. Absorption	16 A
Drive systems	On-board at upper level
Control systems	On-board
Reference standard	CE Mark - In compliance to BS6440-2011 and D.M. 2006/42/CE

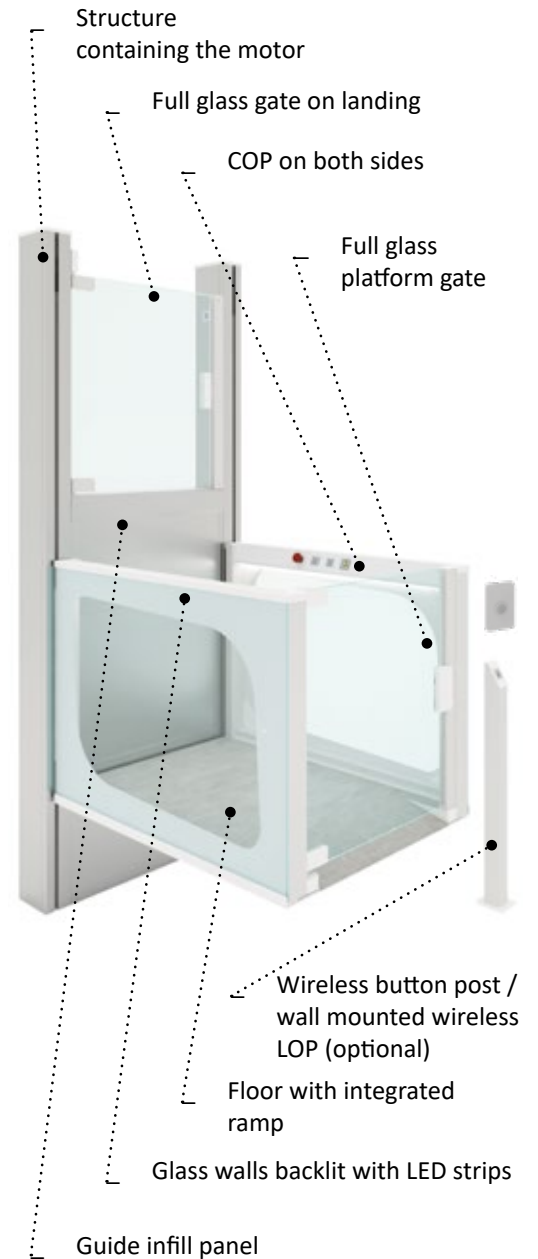

## Dimensions

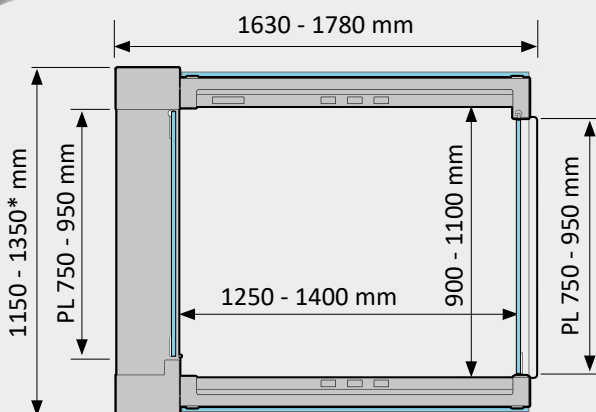

\* Allow at least 400 mm of free space on both sides for maintenance

## Safeties

- ⊠ Anti-crushing sensitive bottom under the platform
- ⊠ Front side anti-shearing wall
- ⊠ Safety gear
- ⊠ Overload and belt loosening sensor
- ⊠ Electric lock locking control
- ⊠ Automatic emergency descent operated on board with UPS system in case of power outage
- ⊠ STOP button for emergency stop
- ⊠ Acoustic ALARM button on board
- ⊠ Emergency light
- ⊠ Disabling key ON / OFF at upper level
- ⊠ Autodialler (optional)
- ⊠ Motion buzzer (optional)

# DomoStep 100A

Open platform without wall fixings



## Versatile solution

DomoStep 100A is the ideal solution to overcome architectural barriers **up to one metre in complete safety**. It is designed for people with reduced mobility and using a wheelchair, with or without an accompanying person.

Safety, versatility and reliability, reduced overall dimensions and quick installation are DomoStep 100A strengths.

The platform, in compliance with Machinery Directive 2006-42-CE, does not need any building work; it is battery-powered and does not require any fixed wiring. A standard socket is enough.





Suggested use



Max payload



Stand-By power consumption



In-use power consumption



# DomoStep 100A

## Finishes

### Steel structure painting

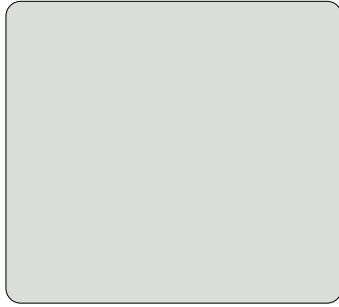

**RAL 7035**  
Light grey - **Standard**



**RAL Painting**  
AreaLift range

### Floors

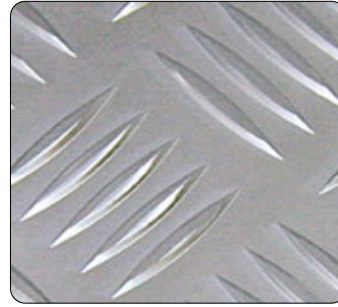

**Aluminium - 5 bar aluminium**  
tread plate - **Standard**

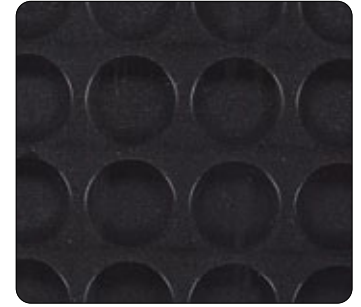

**N004**  
Black round studded rubber

## Configuration

### Safety

- Emergency STOP
- Lowering to landing in case of power outage
- Lower sensitive underpan (without bellows)
- Battery powered

### Platform operating panel

- Standard with n° 5 buttons

### Wireless operating panel (kit 2 pieces)

- N° 1 button
- N° 1 hold-to-run key
- N° 1 button + 1 key switch 2P/2E

### Landing gate

- BL Blank (painted RAL 7035 Light Grey)
- BL Blank (painted RAL in AreaLift range)
- GL Glazed
- Powered gate opening system

■ Standard  Optional

### Protection bellow (in compliance with the current directive)

- 85 mm pit

### Protection bar and handlebars

- side fixed handlebar
- Automatic fall-prevent bar

### Finishes (balustrade, anti-shearing wall, platform, column and accessories)

- BL Blank (painted RAL 7035 Light Grey)
- BL Blank (painted RAL in AreaLift range)

### Platform

- Customised dimensions (within max limits)
- 5 Bar Aluminium tread plate floor
- Round Studded Rubber black floor

### Extra version

- OUTDOOR - AISI 316 stainless steel
- OUTDOOR - Electric and Mechanical protection

## Dimensions

### STANDARD VERSION

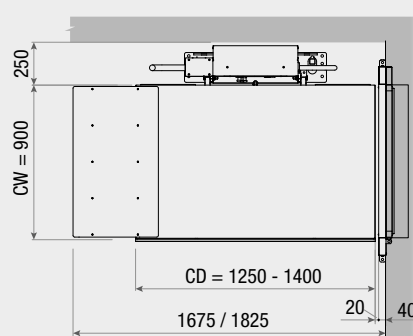
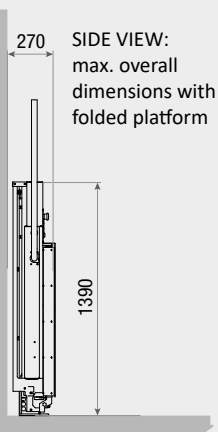

TOP VIEW: max overall dimensions  
with unfolded platform

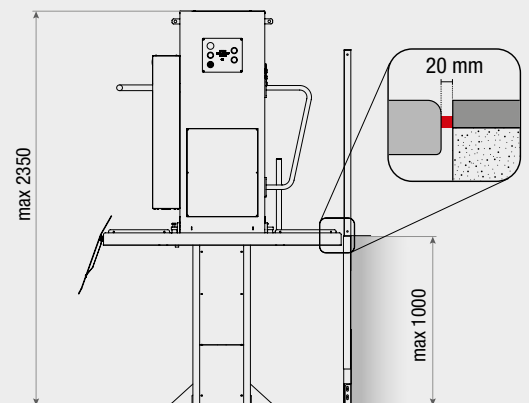

FRONT VIEW:  
overall height at max extension

# Technical specifications

Maximum travel (H max)	1000 mm
Drive	Hydraulic
Operation	Hold to Run
Speed	0.05 m/s (5 cm per second)
Power supply	Single-phase 230 Vac
Stand-by power consumption	6 W (electrical network supply)
In-use power consumption	46W (electrical network supply)
Cycles /hour	Max 10 (with 250 kg load)
Temperatures range	-5°C / + 40°C
Batteries	2 x 12Vdc 7Ah
Power Unit	Embedded in the column
Platform	Manually foldable (version without balaustrade)
Platform dimensions (L1xL2)*	900x1250 - 900x1400 mm
Remote control	Included (2 pcs)
Fixing (travel ≤ 0.5 m)	Floor fixing
Fixing (travel ≤ 1.0 m)	Floor and wall fixings
Packaging	Wooden box

\* Customized dimensions (on demand)

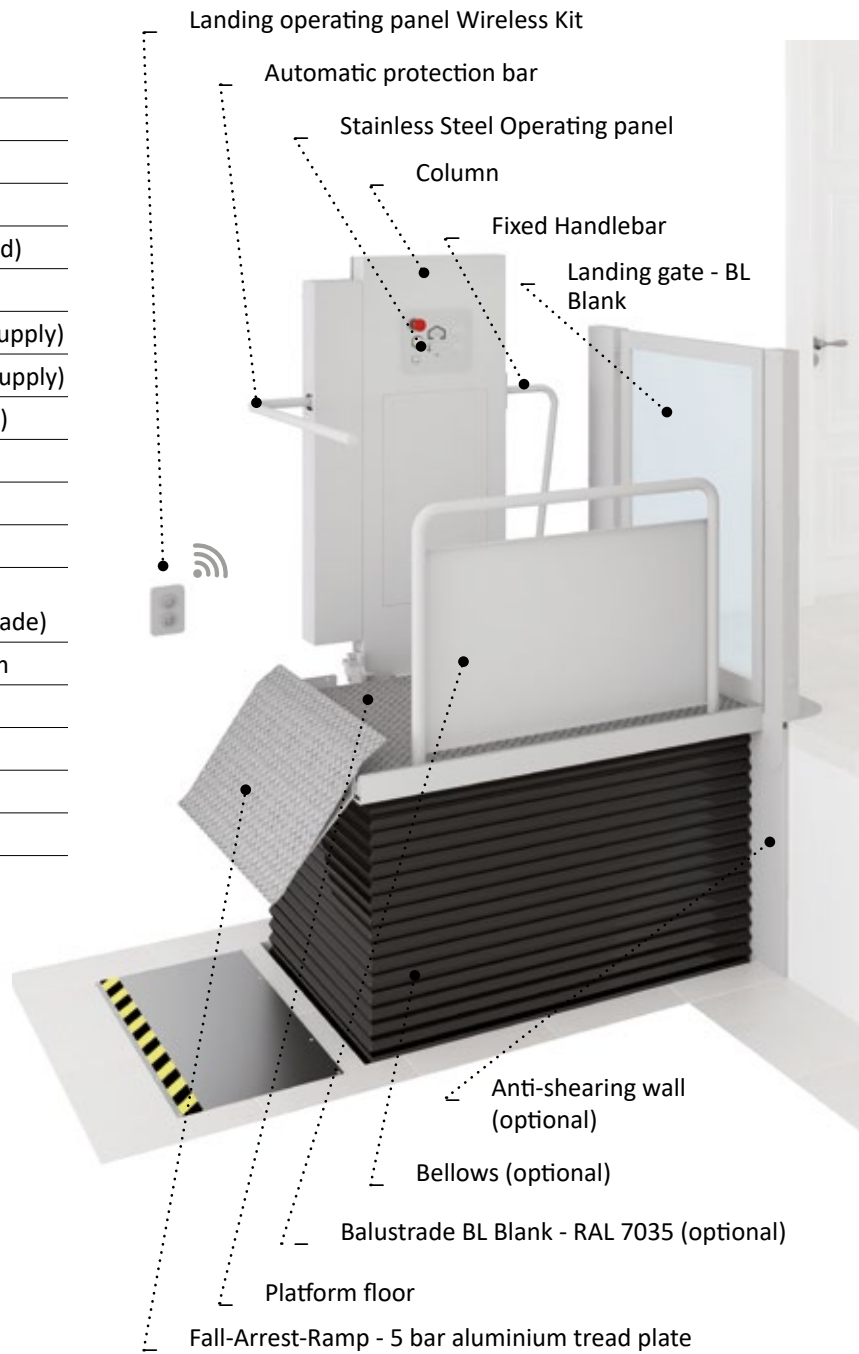
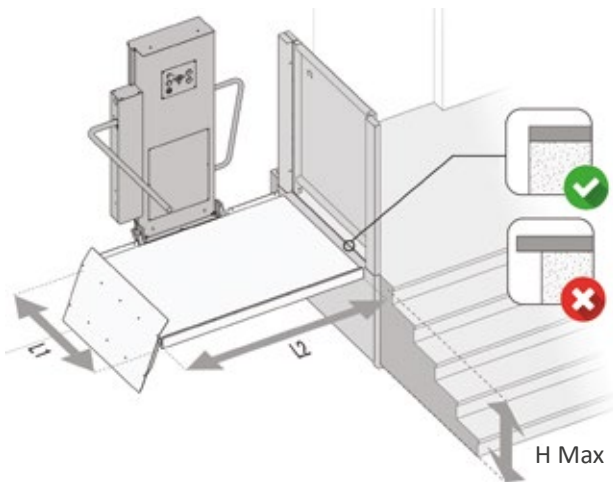

## BELLOWS VERSION (OPTIONAL)

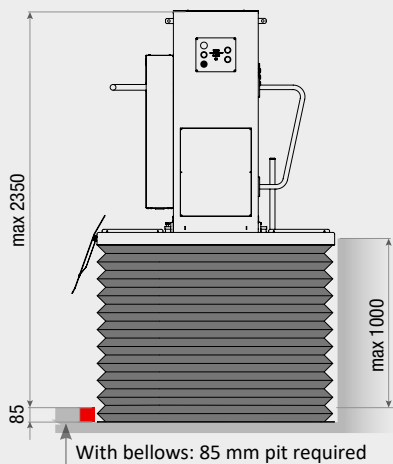
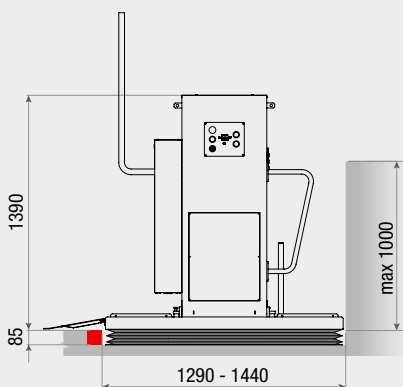

## Who we are

AreaLift is a young company established by professionals with long experience in the vertical transport sector.

AreaLift is specialised in the design and production of home and platform lifts to overcome differences in height up to 15 metres.

Our products are sold in over 45 countries worldwide!

## Made in Italy

What makes us unique is the Italian style and the attention to quality which comes from our history as a manufacturing company.

Functional and comfortable, AreaLift's lifting platforms allow the user to move easily, in perfect autonomy and with the charm that distinguishes the Italian style.

## LiftingItalia and AreaLift

The group consists of two young and dynamic companies that work in perfect synergy complementing each other.

LiftingItalia - Established in 2003, is the parent company and today is specialised in the production of **high quality homelifts**.

AreaLift - Established in 2006, is a company **specialised in accessibility solutions and vertical mobility**.



### AREALIFT S.r.l.

Via Caduti del Lavoro, 22  
43058 Bogolese di Sorbolo - Parma, Italy  
Tel. +39 0521 695311

[www.arealift.com](http://www.arealift.com)



Authorized reseller